

ITEM NO.:

Description: Double Wall Sconce

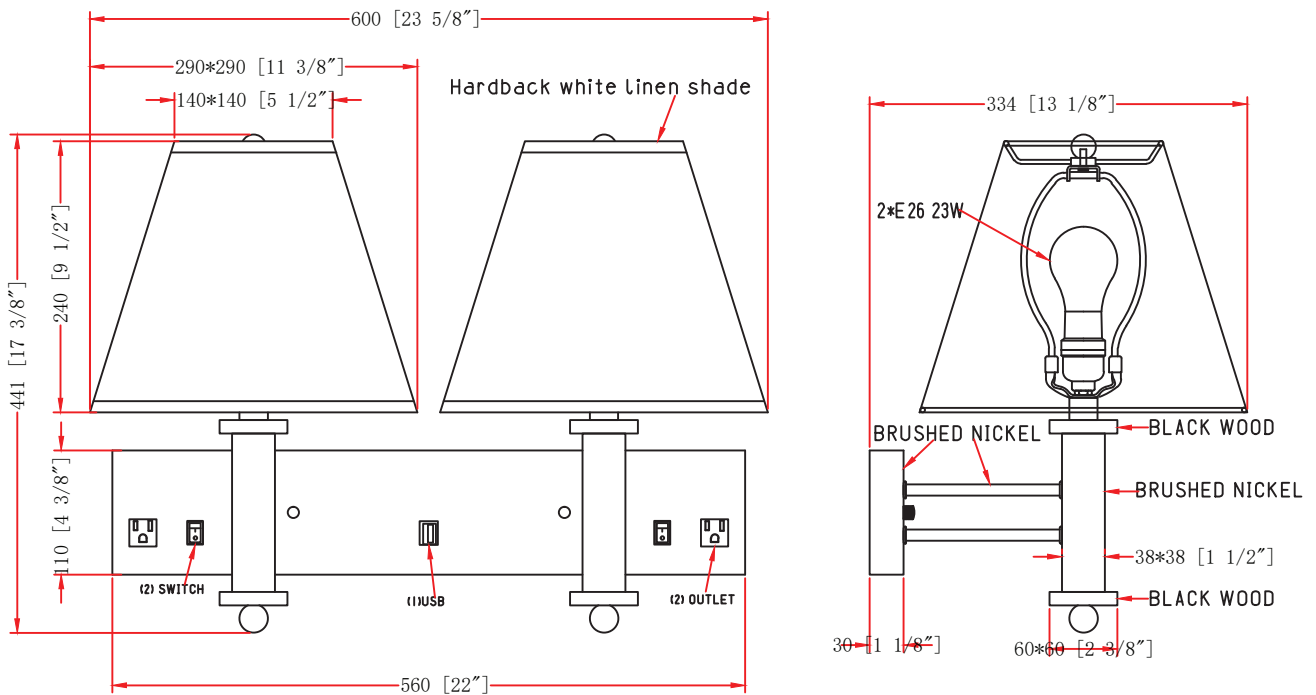

LINE DRAWING



STANDARD FEATURES:

- Double Wall Sconce
- UL APPROVED FOR DRY LOCATION
- MATERIAL: STEEL+CLOTH+WOOD
- USE 120V 60HZ AC
- LAMP/WATT: 2\*E26 23W

FIXTURE DATA

MODEL NO.	FINISH	SHADE	SIZE			TYPE OF LAMPS
			WIDTH	HEIGHT	EXTENSION	
US-551WD-USB	Brushed Nickel	Hardback white linen shade	23.625"	17.375"	13.125"	2*E26 23W

LIGHT BULB DATA

BULB TYPE	BASE TYPE(SOCKET)	WATTAGE RATED	RATED LIFE (Hours)	Approx. LIGHT (Lumens)	Approx. Color (Temp. K)	Luminous efficacy (LM/W)	CRI
E26		23W					

