

ITEM NO.:

Description: Double Wall Sconce

LINE DRAWING

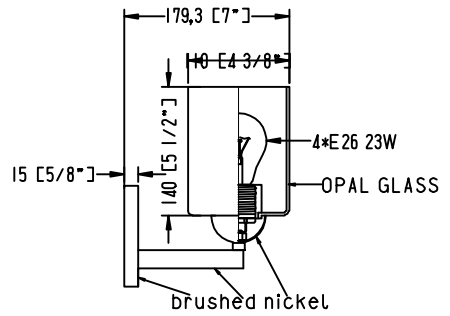
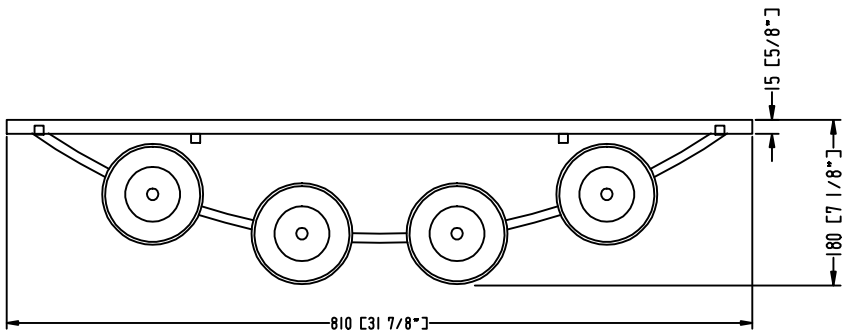
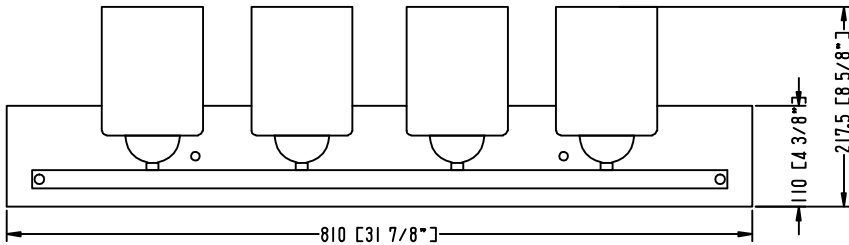
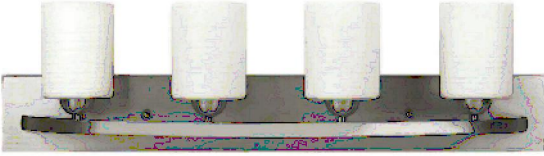

STANDARD FEATURES:

- Double Wall Sconce
- UL APPROVED FOR DRY LOCATION
- MATERIAL : STEEL+GLASS
- USE 120V 60HZ AC
- LAMP/WATT: 4*E26 23W

FIXTURE DATA

MODEL NO.	FINISH	SHADE	SIZE			TYPE OF LAMPS
			WIDTH	HEIGHT	EXTENTION	
US-7044	Brushed Nickel	OPAL GLASS	31.875"	8.625"	7.125"	4*E26 23W

LIGHT BULB DATA

BULB TYPE	BASE TYPE(SOCKET)	WATTAGE RATED	RATED LIFE (Hours)	Approx. LIGHT (Lumens)	Approx. Color (Temp. K)	Luminous efficacy (LM/W)	CRI
E26		23W					

